



**MBV SERIES  
3-WAY BALL VALVES**





**VAHN-TECH International Inc.**, headquartered in Toronto, Canada is a unique company within the Flow Control Industry.

- ✳ 'vt' brand = high quality certified products (API, NSF, CSA, WRAS etc.)
- ✳ Valves, Actuators and Accessories – all 'vt' branded
- ✳ Width and Depth of Product Offerings
- ✳ Flexibility to customize products to customer needs
- ✳ Specialized user-friendly products including large sizes
- ✳ Quick Response
- ✳ Reduced Delivery times
- ✳ Efficient after sales service
- ✳ Competitive Pricing

**VAHN-TECH International Inc.** is a customer focused organization based on “Value-Add” and “Quality Service” principles. Achieving long term partnership with our customers and being their supplier of choice is our prime mission.

We develop, manufacture and market VAHN-TECH (vt) branded Valves, Actuators, Automatic Control Valves and Accessories for variety of Industrial Applications. Our product range includes:



**Oil and Gas**



**Water and Sewage,  
Desalination**



**Chemicals**



**Paper and Pulp**



**Irrigation**



**Power Plants**



**Various  
Industrial Applications**

We can supply all types of valves with following materials of construction like:

Ductile Iron, Cast Iron, Carbon Steel, Stainless Steel – SS304, SS304L, SS316, SS316L, Duplex Stainless Steel, Super Duplex, Alloy, Monel and Inconel with variety of seating and stem configurations.



**Intertek**

## 1. Design Standards

Applicable Standards	
Design:	API 6D, API 608, BS 5351, CSA Z245.15
Testing:	API 6D, API 598
End Connection:	ASME B16.5, ASME B16.47
Wall Thickness:	ASME B16.34
Firesafe:	API 607, API 6FA
NACE:	MR 0175, MR 0103

## 2. Product Range

Product Range	
Size:	2" to 24"
Nominal Pressure:	Cast Body (Floating Ball): Class 150 to Class 300 Forged Body (Trunnion Ball): Class 150 to Class 2500
Temperature Range:	-46°C to 220°C (higher temperature & cryogenic applications available on request)
Body Material:	Carbon Steel, Low Temperature Carbon Steel, Stainless Steel, Alloy Steel, Duplex Stainless Steel
Seat Material:	Soft Seat: (R)PTFE, NYLON, DEVLON, PCTFE, PEEK Metal Seat: STL, TC

## 3. Design Features

Three-way ball valves are used to switch over, mix and divide the flow of corrosive or non-corrosive liquid, steam or gas media. VAHN-TECH three-way ball valves are durable, versatile and cost-effective use in Chemical, Oil & Gas, Desalination or LNG application. Upon opening and closing, the smooth flow channel reduces the pressure loss. There are five choices of flow direction (1 for L-shaped and 4 for T-shaped) to meet each specific applications. VAHN-TECH three-way valves are easy to maintain, reducing the overall cost of operation. VAHN-TECH offers 2 design for 3-way valves: Floating ball design with cast body and Trunnion ball design with forged body. Forged body design is ideal for higher pressure operation, abrasive and corrosive media.

### Charteristics

1. Valve seat can be designed with three-side seated floating ball or four-side seated trunnion ball, with smooth fluid state and reliable seal;
2. Anti-blow out stem design;
3. Anti-static design;
4. Two position locking mechanism.

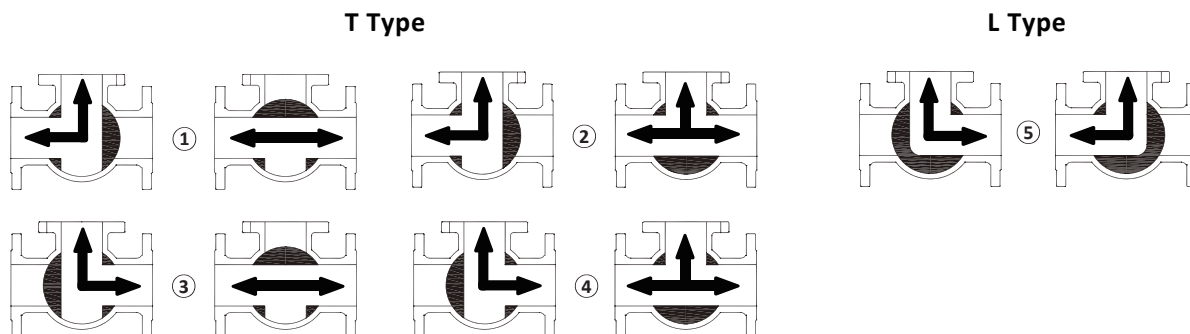

## Reliable Seat Sealing Structure

For the Trunnion Mounted 3-Way Ball Valves, four floating seat retainers are used for the seat sealing. They float axially to seal against the ball. High pressure sealing is realized by pressure assisted mechanism while a pre-loaded spring ensure tight sealing under very low differential pressure in both soft and metal seated configuration. The seat insert for soft seated configuration is made of thermoplastic material with multiple options depending on the actual operating conditions.

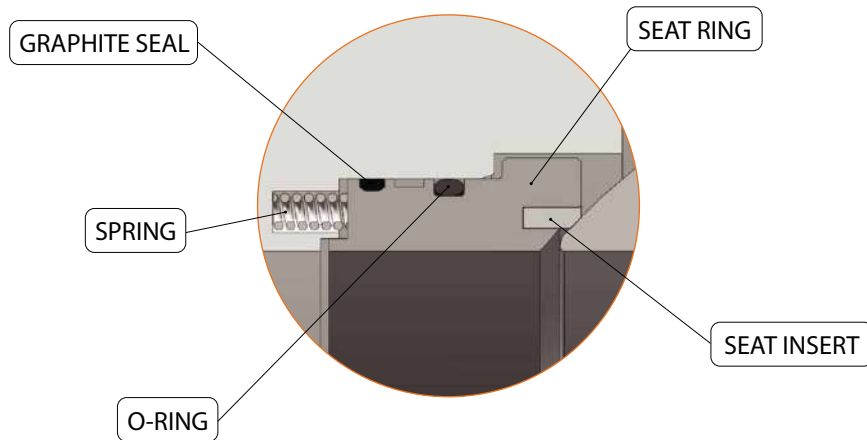

## Blow Out Proof Stem

The design of the one-piece stem includes a step preventing blow out, even during maintenance operation or incidental cavity pressure rise.

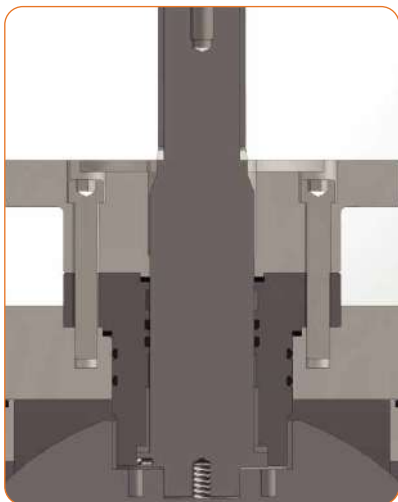

## Anti-Static Device

During on-off operations, friction between ball and non-metal seat can produce electro static charge that can accumulate on ball surface. To prevent static sparks - antistatic devices (ball loaded spring/springs) are assembled between stem & ball and stem & top flange to permit electric conductivity through all metallic components.

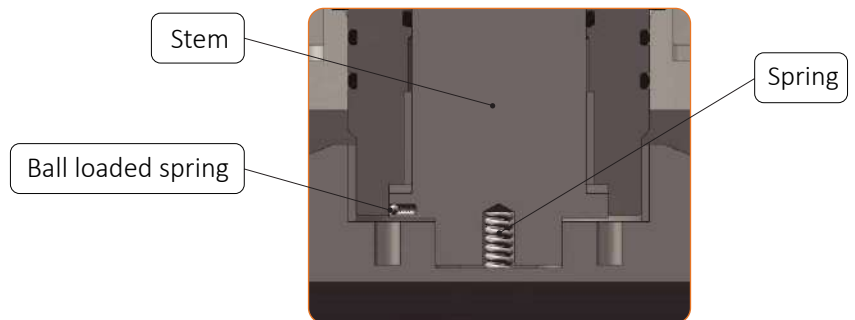

## 4. Material Selection Example

Below is some example of material selection and valve configuration for forged 3-Way Ball Valves based on different service applications. Contact us for support in selecting the most adequate configuration for your operations.

Service	Non-corrosive	Low Temperature	Corrosive	Sour	
Body/Cap	ASTM A105	ASTM A350 LF2	ASTM A182 F316	ASTM A182 F51, S31803	ASTM A182 F55, S32760
Stem	ASTM A182 F6a	ASTM A182 F316	ASTM A182 F316	ASTM A182 F51, S31803	ASTM A182 F55, S32760
Ball	ASTM A105 + ENP	ASTM A350 LF2 + ENP	ASTM A182 F316	ASTM A182 F51, S31803	ASTM A182 F55, S32760
Seat Retainer	ASTM A105 + ENP	ASTM A350 LF2 + ENP	ASTM A182 F316	ASTM A182 F51, S31803	ASTM A182 F55, S32760
Seat	(R)PTFE (CLASS 150 to 600) and NYLON (CLASS 900 and over)				
Spring	INCONEL X750				
O-Ring	HNBR	FKM	FKM	FKM	FKM
Bolt	ASTM A193 B7	ASTM A193 B8M	ASTM A193 B8M	ASTM A193 B8M	ASTM A193 B8M
Nut	ASTM A194 2H	ASTM A194 8M	ASTM A194 8M	ASTM A194 8M	ASTM A194 8M

## 5. Cast 3-Way Ball Valve

### 5a. Materials of Construction

No.	Parts
1	Body
2	Bonnet
3	Ball
4	Sealing Ring
5	Gasket
6	Studs
7	Nut
8	Sealing Ring
9	Sealing Ring
10	Seat
11	O-Ring
12	Plug Screw
13	Stem
14	Gasket
15	Packing
16	Studs
17	Packing Gland
18	Spacer / Position Indicator
19	Circlip
20	Lever

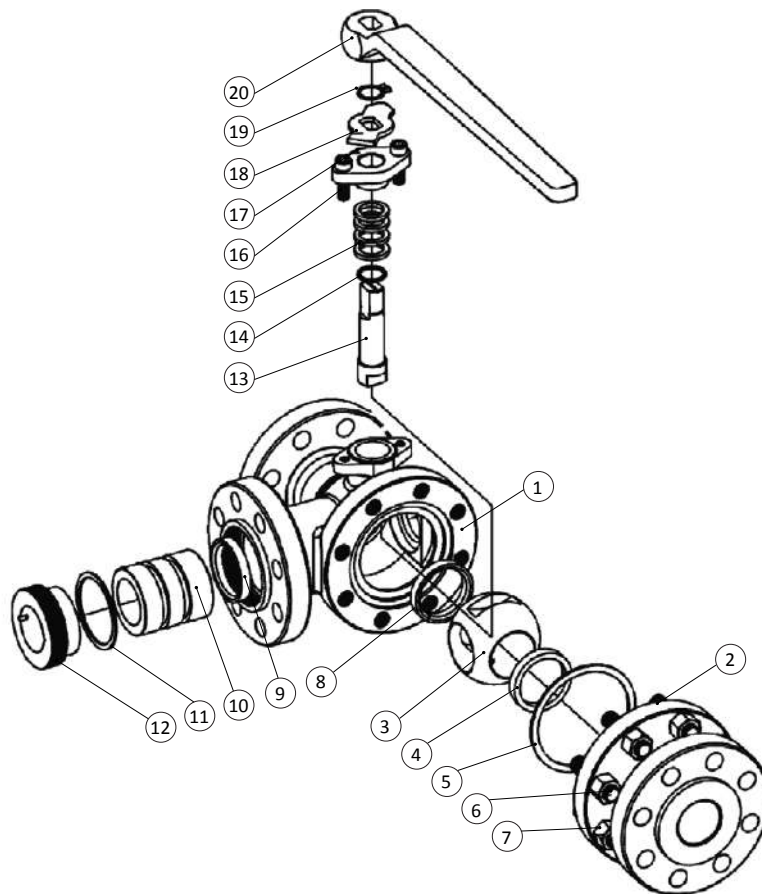

## 5b. Dimensions

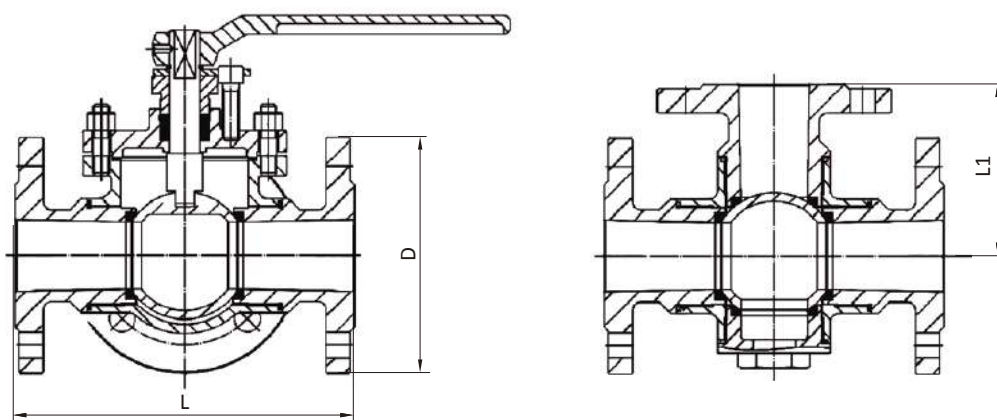

### Class 150

Size		Dimension (inch)		
NPS	DN	L	L1	D
1/2"	15	5.5	2.75	3.5
3/4"	20	5.9	3.0	3.9
1"	25	6.3	3.1	4.3
1 1/2"	40	8.3	4.1	5.0
2"	50	8.7	4.3	6.0
2 1/2"	65	9.8	4.9	7.0
3"	80	10.2	5.1	7.5
4"	100	13.0	6.5	9.0
5"	125	16.9	8.5	10.0
6"	150	20.0	10.0	11.0
8"	200	22.8	11.4	13.5
10"	250	26.4	13.2	16.0

Size		Dimension (mm)		
NPS	DN	L	L1	D
1/2"	15	140	70	89
3/4"	20	150	75	99
1"	25	160	80	108
1 1/2"	40	210	105	127
2"	50	220	110	152
2 1/2"	65	250	125	178
3"	80	260	130	190
4"	100	330	165	229
5"	125	430	215	254
6"	150	510	255	279
8"	200	580	290	343
10"	250	670	335	406

### Class 300

Size		Dimension (inch)		
NPS	DN	L	L1	D
1/2"	15	5.5	2.75	3.75
3/4"	20	6.5	3.2	4.6
1"	25	6.5	3.2	4.9
1 1/2"	40	9.8	4.9	6.1
2"	50	10.2	5.1	6.5
2 1/2"	65	12.6	6.3	7.5
3"	80	12.6	6.3	8.3
4"	100	14.6	7.3	10.0
5"	125	20.0	10.0	11.0
6"	150	20.0	10.0	12.5
8"	200	22.8	11.4	15.0
10"	250	26.4	13.2	17.5

Size		Dimension (mm)		
NPS	DN	L	L1	D
1/2"	15	140	70	95
3/4"	20	165	82.5	117
1"	25	165	82.5	124
1 1/2"	40	250	125	155
2"	50	260	130	165
2 1/2"	65	320	160	190
3"	80	320	160	210
4"	100	370	185	254
5"	125	510	255	279
6"	150	510	255	318
8"	200	580	290	381
10"	250	670	335	444

## 6. Forged 3-Way Ball Valves

### 6a. Materials of Construction

No.	Parts
1	Body
2	Bonnet
3	Ball
4	Composite Bearing
5	Washer
6	Composite Bearing
7	Small Ball
8	Small Spring
9	Stem
10	O-Ring
11	Gasket
12	Bonnet
13	Studs
14	Nut
15	O-Ring
16	Gasket
17	Top Flange
18	Socket Head Cap Screw
19	Cylindrical Pin
20	Stem Grease Injection
21	Blind Bonnet
22	Bleed Valve
23	Drain Valve
24	Composite Bearing

No.	Parts
25	O-Ring
26	Gasket
27	Lower Stem
28	Socket Screw
29	Sealing Ring
30	Seat
31	O-Ring
32	Seat Fire Proof Graphite Braided Rope
33	Spring
34	O-Ring
35	Gasket
36	Studs
37	Nut

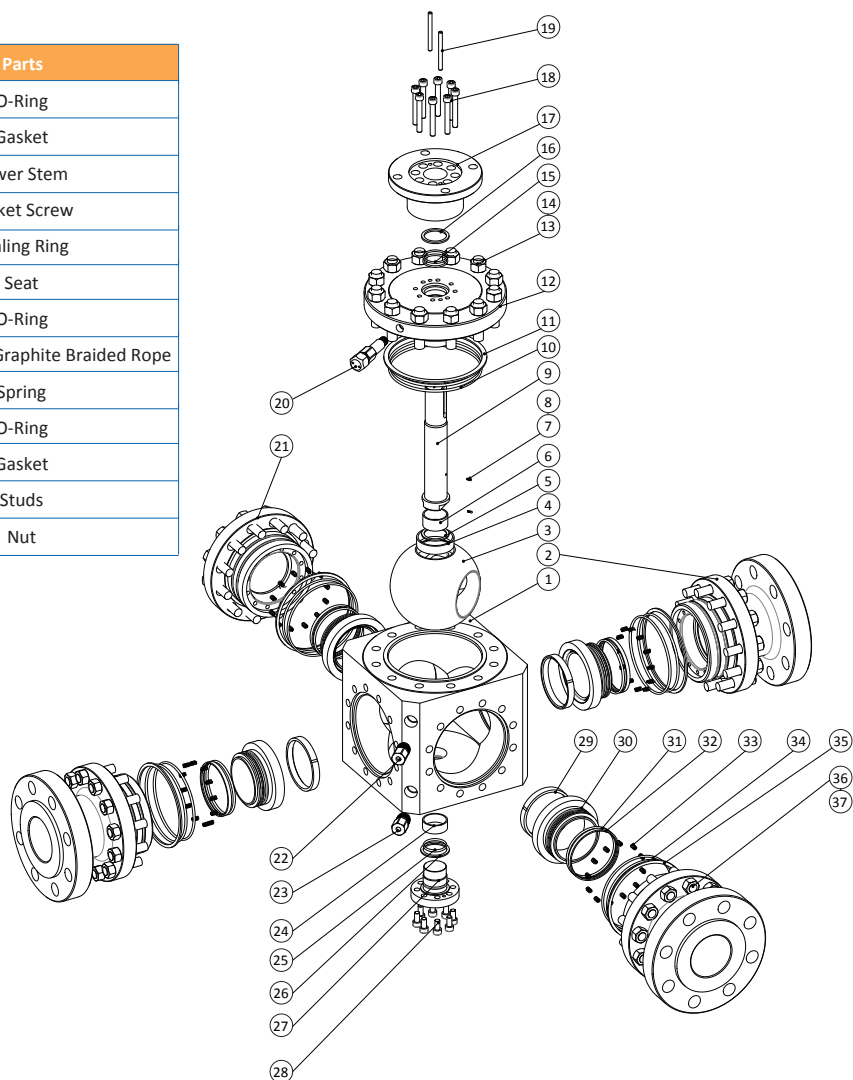

### 6b. Dimensions

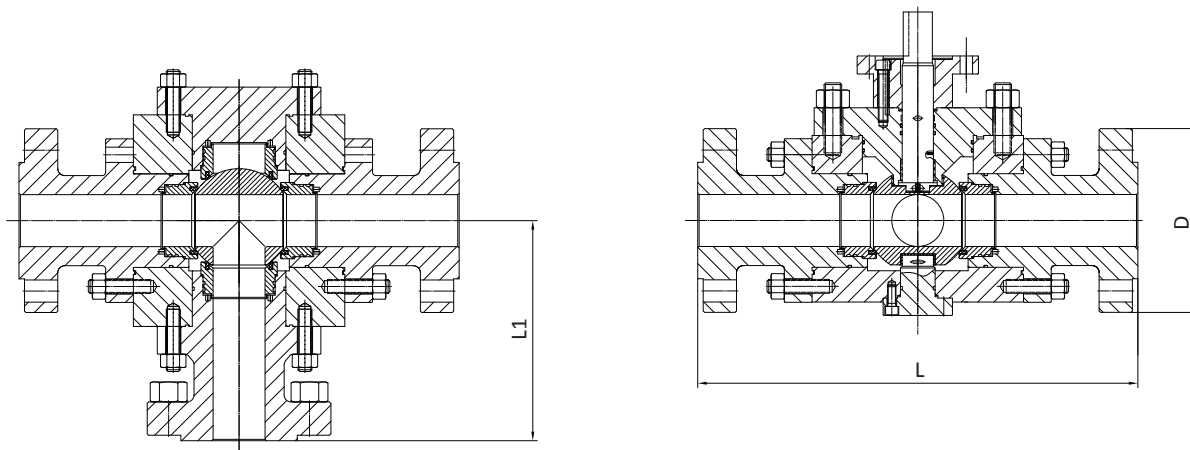

### Class 150

Size		Dimension (inch)		
NPS	DN	L	L1	D
2"	50	11.4	5.7	6.0
2 1/2"	65	13.5	6.7	7.0
3"	80	15.0	7.5	7.5
4"	100	16.9	8.5	9.0
6"	150	19.3	9.6	11.0
8"	200	23.6	11.8	13.5
10"	250	30.5	15.3	16.0
12"	300	33.5	16.7	19.0
14"	350	40.4	20.2	21.0
16"	400	45.4	22.6	23.5
18"	450	50.2	25.0	25.0
20"	500	55.1	27.6	27.5
24"	600	63.0	31.5	32.0

Size		Dimension (mm)		
NPS	DN	L	L1	D
2"	50	290	145	150
2 1/2"	65	340	170	180
3"	80	380	190	190
4"	100	430	215	230
6"	150	490	245	280
8"	200	600	300	345
10"	250	775	387.5	405
12"	300	850	425	485
14"	350	1025	512.5	535
16"	400	1150	575	595
18"	450	1275	637.5	635
20"	500	1400	700	700
24"	600	1600	800	815

### Class 300

Size		Dimension (inch)		
NPS	DN	L	L1	D
2"	50	11.4	5.7	6.5
2 1/2"	65	13.5	6.7	7.5
3"	80	15.0	7.5	8.3
4"	100	16.9	8.5	10.0
6"	150	19.3	9.6	12.5
8"	200	23.6	11.8	15.0
10"	250	30.5	15.3	17.5
12"	300	33.5	16.7	20.5
14"	350	40.4	20.2	23.0
16"	400	45.4	22.6	25.5
18"	450	50.2	25.0	28.0
20"	500	55.1	27.6	30.5
24"	600	63.0	31.5	36.0

Size		Dimension (mm)		
NPS	DN	L	L1	D
2"	50	290	145	165
2 1/2"	65	340	170	190
3"	80	380	190	210
4"	100	430	215	255
6"	150	490	245	320
8"	200	600	300	380
10"	250	775	387.5	445
12"	300	850	425	520
14"	350	1025	512.5	585
16"	400	1150	575	650
18"	450	1275	637.5	710
20"	500	1400	700	775
24"	600	1600	800	915

### Class 600

Size		Dimension (inch)		
NPS	DN	L	L1	D
2"	50	15.4	7.7	6.5
2 1/2"	65	18.3	9.2	7.5
3"	80	18.9	9.4	8.3
4"	100	21.3	10.6	10.0
6"	150	27.8	13.9	12.5
8"	200	31.1	15.6	15.0
10"	250	42.3	21.2	17.5
12"	300	43.3	21.7	10.5

Size		Dimension (mm)		
NPS	DN	L	L1	D
2"	50	392	196	165
2 1/2"	65	465	232.5	190
3"	80	480	240	210
4"	100	540	270	275
6"	150	705	352.5	355
8"	200	790	395	420
10"	250	1075	537.5	510
12"	300	1100	550	560

🍁 Contact us for larger diameter with pressure Class 900 / Class 1500 / Class 2500.



## 7. Actuation and Operation

VAHN-TECH Three-way Ball Valves are designed for both manual operation with gearbox and automatic operation. Our valves are designed to minimize the operating torque and allow for easy mounting of valve automation - electrical, pneumatic or hydraulic. All our valves are designed with ISO 5211 compliant top flange.

VAHN-TECH can provide complete automated valve package. We manufacture a full range of CSA certified quarter-turn and failsafe/spring return electrical actuators for normal indoor/outdoor operation and explosion proof area. We also manufacture rack and pinion pneumatic actuators and scotch yoke actuators. All VAHN-TECH actuators can be modified at the factory to allow for 180 degrees operation for specific T-port operations. We can install and test all automation accessories, Limit Switch, Air filter, Solenoid Valve, Fire fusible, Quick exhaust, etc.

Contact us for your tailor-made automation solution.



Electric Actuator



Pneumatic Actuator



Gearbox

## 8. Engineering Data

### 8.1 Temperature Pressure Curve

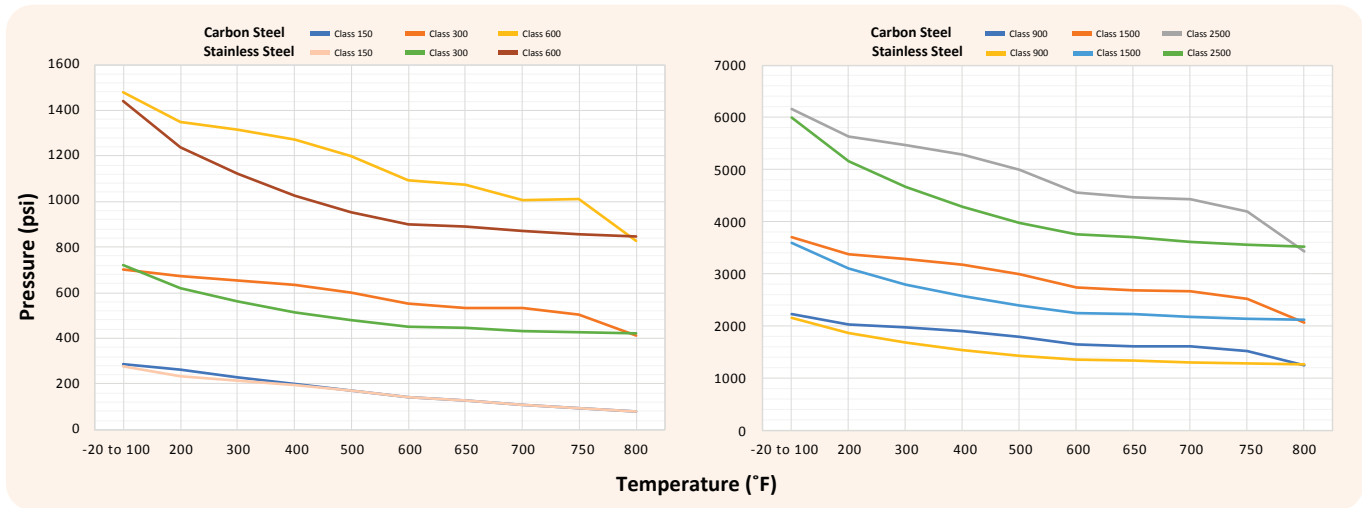

### 8.2 Sealing Material Selection

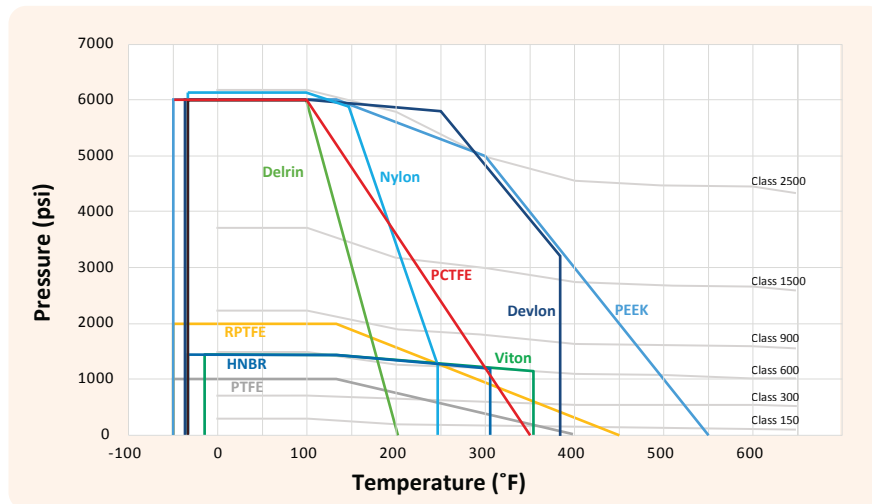

Materials	Temperature	Application
PTFE	-50°F to 400°F -46°C to 204°C	Made from Virgin Teflon, Polytetrafluoroethylene (PTFE) is a thermoplastic fluoropolymer that consists of Carbon and Fluorine. PTFE structure is compatible to most chemicals and is suitable for almost all media.
(R)PTFE	-50°F to 450°F -46°C to 232°C	15% glass reinforced PTFE, RTFE has improved wear and abrasion resistance over PTFE and higher temperature resistance. Chemical resistance is equivalent to virgin PTFE. RPTFE is the standard seat material for Ball Valves up to Class 600.
Devlon	-58°F to 375°F -50°C to 191°C	Devlon, a polyamide, is one of the toughest and hardest wearing thermoplastics available. It provides wear resistance, impact strength, and low moisture absorption properties.
PCTFE	-324°F to 356°F -198°C to 180°C	PCTFE is a homopolymer of chlorotrifluoroethylene, featuring high compressive strength and low deformation under load. Recommended for cold service with good resistance to violent temperature fluctuations. It is good for cryogenic service down to -198°C.
PEEK	-50°F to 550°F -46°C to 288°C	PEEK (Polyether Ether Ketone) is best suited for high temperature and pressure service while exhibiting good chemical resistance.
UHMWPE (Delrin)	-40°F to 180°F -40°C to 82°C	UHMWPE (Ultra High Molecular Weight Polyethylene) is a semi-crystalline material that possesses superior wear and pressure tolerances. UHMWPE is ideal for abrasive, slurry services or low temperature applications that require no PTFE.
Nylon	-40°F to 248°F -40°C to 120°C	Nylon (polyamide) seats are offered for higher pressure and lower temperature service. They can be used in high temperature air, oil and other gas media but are not suited for strong oxidizing.
Viton (FKM)	-20°F to 356°F -29°C to 180°C	Viton is the best elastomer seal for higher temperature applications. It has good large temperature range and good mechanical properties. It is suitable to halocarbons, aromatics, oils and solvents, but it should not be used on steam.
HNBR	-40°F to 302°F -40°C to 150°C	HNBR has recently been developed to meet higher temperatures than standard NBR while retaining resistance to petroleum based oils.

VAHN-TECH International Inc. reserves the right to change the technical data without prior notice.

# PRODUCT SELECTION

**VT - MBV - X - X - X - X - X - X - X - X - X - X - X**

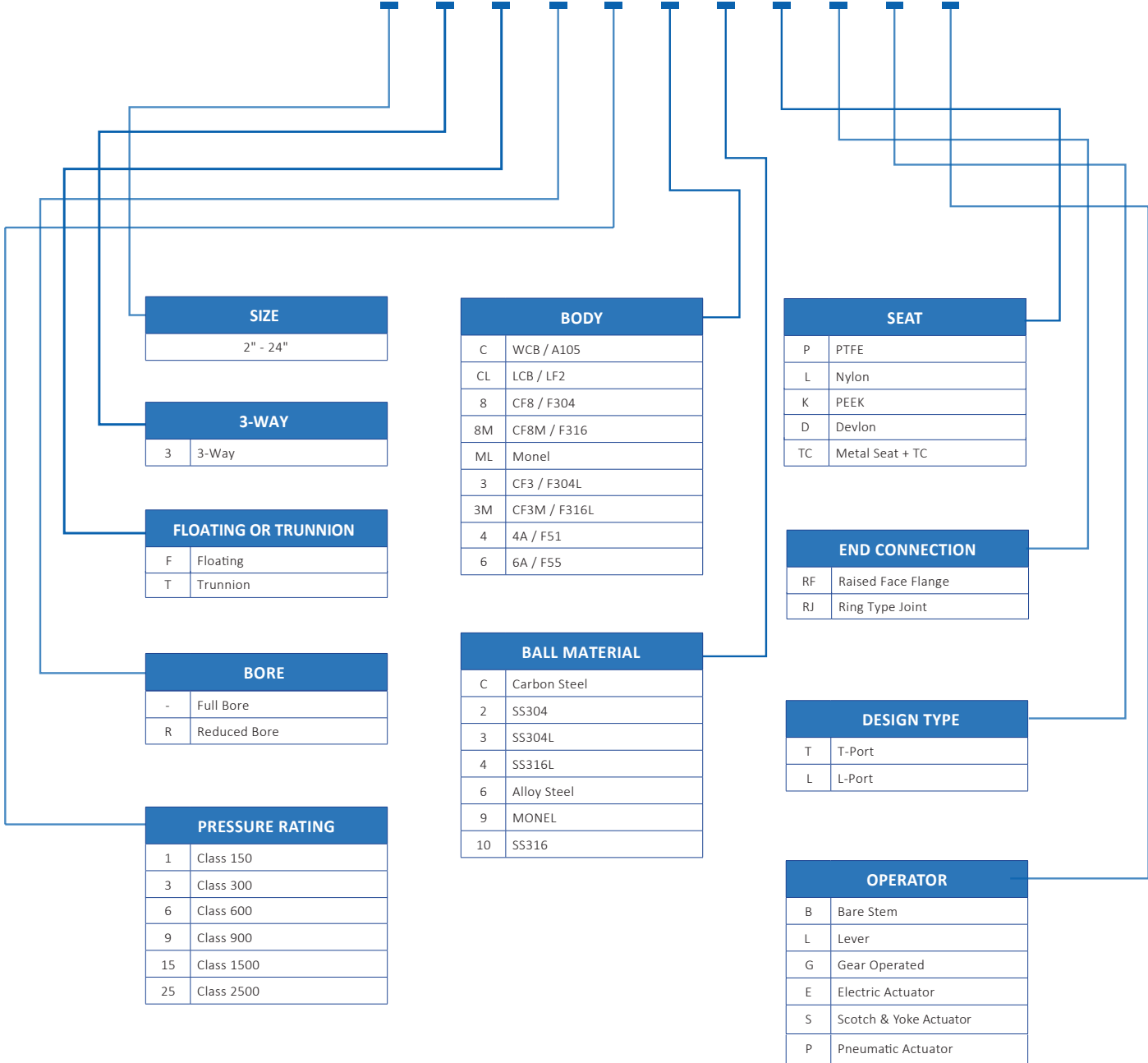



**VAHN-TECH International Inc.**

10-755 Queensway East, Mississauga, ON L4Y 4C5, Canada

Tel.: +1 416 342 0001 E-mail: [info@vahn-tech.com](mailto:info@vahn-tech.com)

[www.vahn-tech.com](http://www.vahn-tech.com)