

AWWA C515 Resilient Seated Gate Valves (Large Diameter)

Resilient Seated gate valves are used as isolation valves for a broad range of applications, including reliable and safe supply of drinking water, service and firefighting water. They are suitable for both above ground and underground installation.

Design Features:

- ✦ Vahn-Tech large diameter resilient seat gate valves meet or exceed AWWA C515 & C509 requirements.
- ✦ High strength ductile iron body used for lowering the weight and improving long term durability.
- ✦ Disc is fully encapsulated in vulcanized EPDM rubber.
- ✦ All iron parts are coated inside & outside with fusion bonded epoxy for corrosion resistance per AWWA C550.
- ✦ Two bearings are added above and below the stem collar to reduce friction.
- ✦ Stem packing is replaceable with valve fully open under operating pressure.
- ✦ Valve can be installed in the horizontal or vertical position.
- ✦ ANSI B16.1 Class 125 and ANSI B16.5 Class 150 flanges are both available.
- ✦ NSF61 approved material available as option.



Typical Applications:

General Water Supply, Fire Fighting, HVAC, District Cooling & Sewage System

Technical Data:

Design Standard:	AWWA C515 / C509
Size Range:	30" – 72"
Pressure Rating:	150 psi
Working Temperature:	-10°C – 80°C
End Connection:	ANSI B16.1 / ANSI B16.5
Face-to-Face:	AWWA C515 / C509
Test & Inspection:	AWWA C515 / C509

Resilient Seat Gate Valves (Non-Rising Stem) 30" - 72"

Parts List & Materials

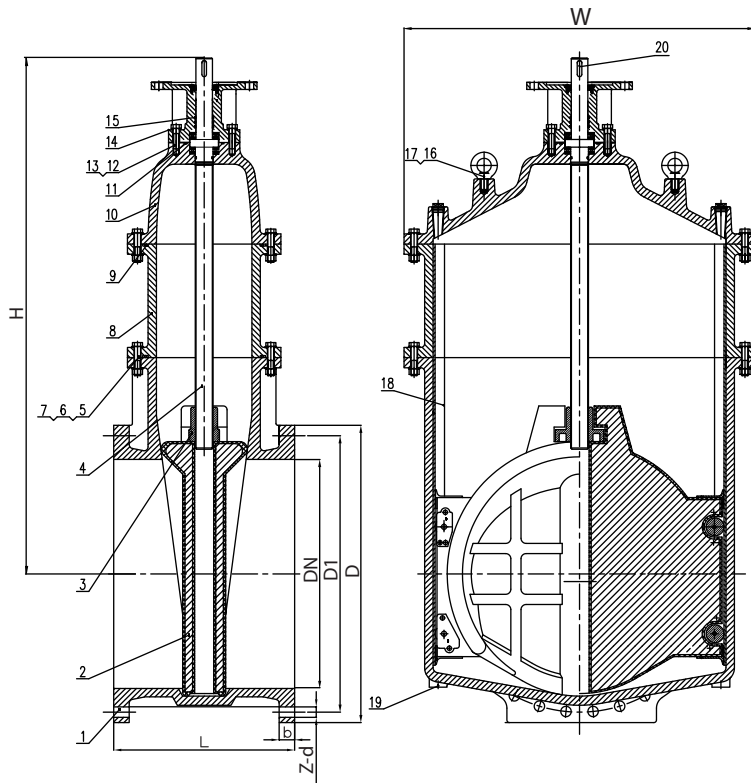

No.	Parts Name	Materials	Standards
1	Body	Ductile Iron	ASTM A536
2	Rubber Wedge	Ductile Iron / EPDM	ASTM A536 / EPDM
3	Stem Nut	Bronze	ASTM B62
4	Stem	Stainless Steel	SS420
5	Bolts	Stainless Steel	SS304
6	Nuts	Stainless Steel	SS304
7	Washer	Stainless Steel	SS304
8	Bonnet Adapter	Ductile Iron	ASTM A536
9	Gasket	EPDM	-
10	Bonnet	Ductile Iron	ASTM A536
11	O-Ring	EPDM	-
12	Bolts	Stainless Steel	SS304
13	Nuts	Stainless Steel	SS304
14	Bearing	Stainless Steel	SS304
15	O-Ring	EPDM	-
16	Lifting Eye	Carbon Steel	-
17	Washer	Stainless Steel	SS316
18	Track	Stainless Steel	SS316
19	Plug (3/4 NPT)	Bronze	ASTM B62
20	Key	Steel	-

Main Dimensions

unit: inch

NPS	D	D1	L	b	H	W	Z-d
30"	38 3/4	36	24	2 1/8	70	47 3/4	28 - 1 3/8
36"	46	42 3/4	28	2 3/8	81	54 1/4	32 - 1 5/8
42"	53	49 1/2	36	2 5/8	86 1/2	66 3/4	36 - 1 5/8
48"	59 1/2	56	44	2 3/4	96	75 1/2	44 - 1 5/8
60"	73	69 1/4	44	3 1/8	128 7/8	84	52 - 1 7/8
72"	86 3/8	82 1/2	48	3 1/2	155 1/2	104 3/4	60 - 2

unit: mm

DN	D	D1	L	b	H	W	Z-d
750	985	914	610	53.8	1778	1213	28 - 35
900	1168	1086	711	61	2057	1378	32 - 41
1050	1345	1257	914	66.5	2197	1695	36 - 41
1200	1510	1422	1118	69.9	2438	1918	44 - 41
1500	1855	1759	1118	79.2	3275	2135	52 - 48
1800	2195	2096	1219	89	3950	2660	60 - 50

Weight

NPS	DN	Weight (kg)
30"	750	2150
36"	900	3600
42"	1050	6500
48"	1200	7500
60"	1500	11500
72"	1800	15000

PRODUCT SELECTION

VT - XX - GV-A15 - X - XX - X - XXX - X - XX - X

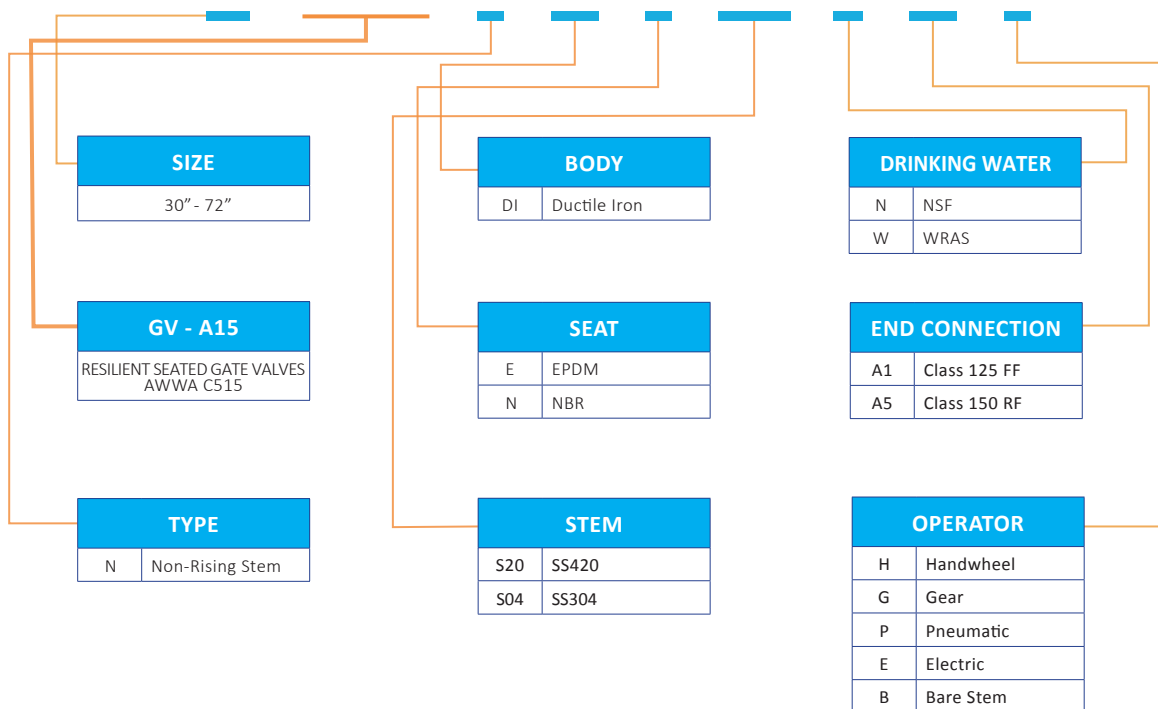

VAHN-TECH International Inc.

10-755 Queensway East, Mississauga, Ontario L4Y 4C5, Canada
Tel.: +1 416 342 0001 E-mail: info@vahn-tech.com

www.vahn-tech.com