

# Q155 PRO SERIES MEDIUM PRESSURE

Maximum Flow Rate: 75 gpm (284 l/min) 2571 BPD  
Maximum Pressure: 3500 psi (241 bar)

 **WANNER™** HYDRA-CELL® PRO  
SEAL-LESS PUMP TECHNOLOGIES

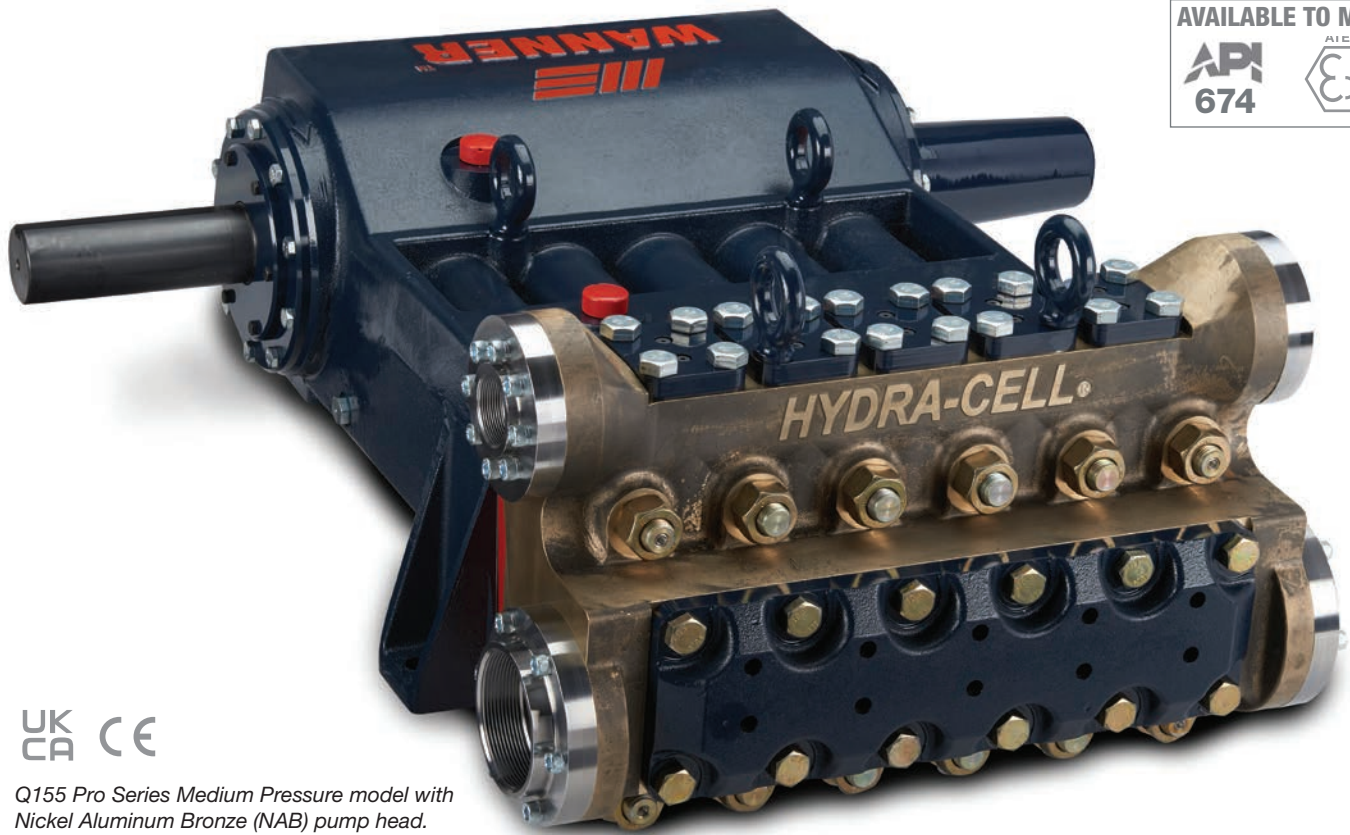

UK  
CA CE

Q155 Pro Series Medium Pressure model with  
Nickel Aluminum Bronze (NAB) pump head.

## A higher standard of pump performance and energy efficiency.

- Integrates **Wanner Hydra-Cell® Pro** seal-less pump technologies for the highest levels of volumetric and energy efficiencies across a full rpm range.
- Patented ADPC (Advanced Diaphragm Position Control) and hydraulic oil management system protect diaphragms under closed or restricted inlet conditions.
- Can run dry indefinitely without damage to the pump.
- Pumped fluid is 100% contained – zero environmental impact, no ground contamination, no volatile emissions.
- Seal-less design eliminates leaks, hazards, and the expense associated with seals and plunger packing.
- Exceeds API 675 standards for accuracy, linearity, and repeatability.
- Reliably handles a wide range of viscosities and shear sensitivities, corrosive fluids, abrasives, slurries and particulates.
- Reduced ownership costs – acquisition, operation, service, maintenance and energy use.

# Q155 Pro Medium Pressure | Performance

## Capacities

Model	Max. Input rpm	Plunger Dia.		Max. Flow Capacities			Max. Pressure Ratings Discharge		Max. Pressure Ratings Inlet	
		inches	mm	gpm	l/min	BPD	psi	bar	psi	bar
Q155K	450	1.750	44	75	284	2571	3000	207	500	34
Q155M	450	1.625	41	63	238	2160	3500	241	500	34

Consult factory when operating below 45 rpm

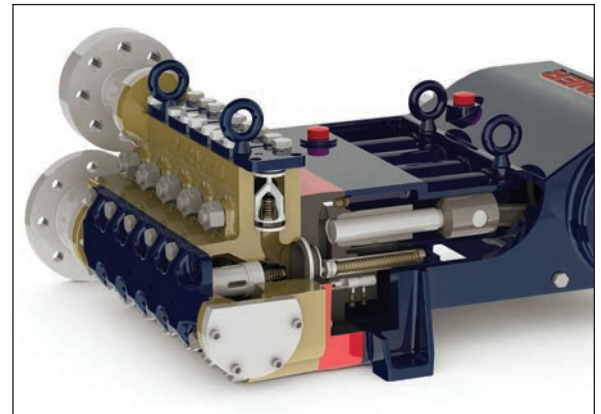
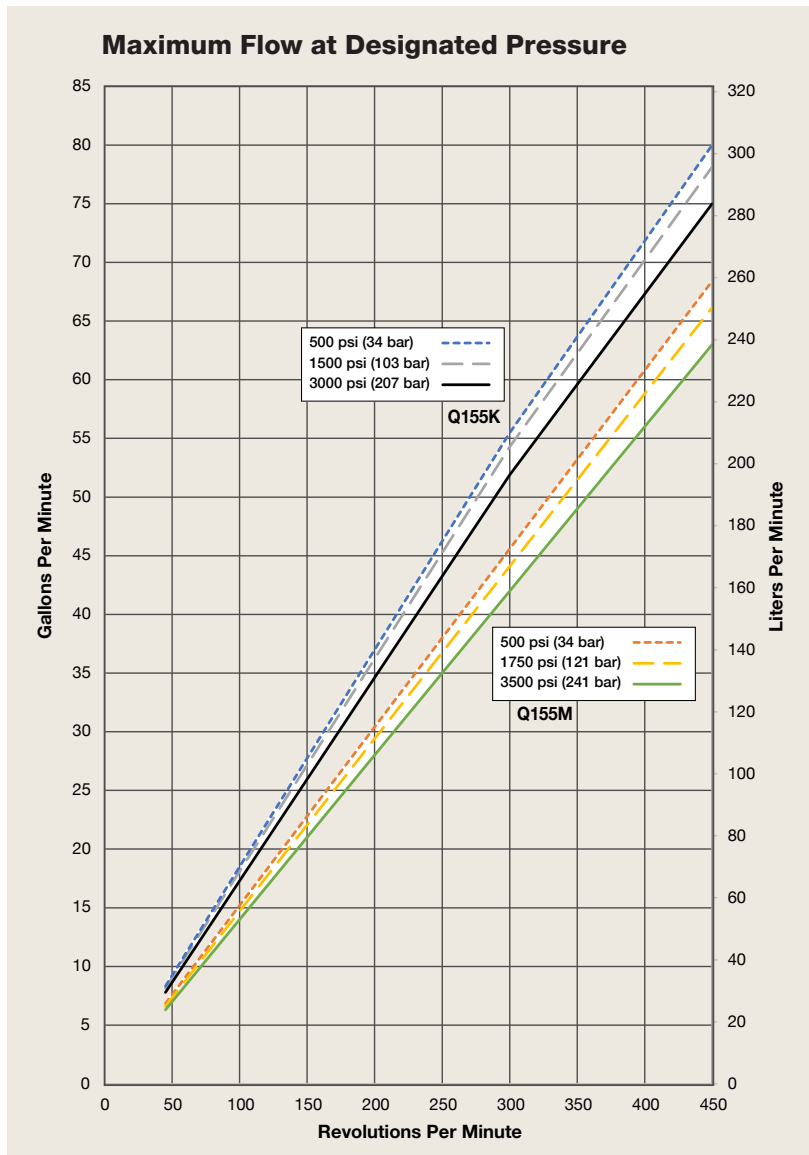

Hydra-Cell Pro Q155 is a positive displacement, multiple-diaphragm pump featuring a seal-less design that provides full containment of the pumping chamber. This means there are no VOC emissions when operating Hydra-Cell and no packing or dynamic seals that pose environmental issues from leakage.

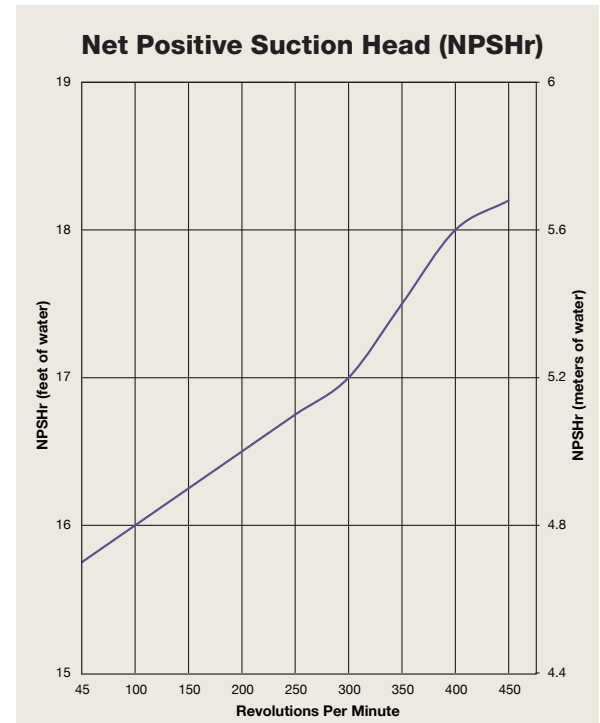

Due to the Wanner Engineering Continuous Improvement Program, specifications and other data are subject to change.

# Q155 Pro Medium Pressure | Specifications

## Flow Capacities

Model	Pressure psi (bar)	rpm	gpm	l/min	BPD
Q155K	3000 (207)	450	75	284	2571
Q155M	3500 (241)	450	63	238	2160

## Delivery

	Pressure psi (bar)	gal/rev	liters/rev
Q155K	500 (34)	0.178	0.674
	1500 (103)	0.174	0.658
	3000 (207)	0.167	0.634

Q155M	500 (34)	0.153	0.579
	1750 (121)	0.148	0.559
	3500 (241)	0.140	0.531

## rpm

Maximum:	450
Minimum:	45

Consult factory for speeds less than 45 rpm.

## Maximum Discharge Pressure

Metallic Heads:	Q155K	3000 psi (207 bar)
	Q155M	3500 psi (241 bar)

**Maximum Inlet Pressure** 500 psi (34 bar)

## Operating Temperature

Maximum:	180°F (82.2°C)
Minimum:	40°F (4.4°C)

Consult factory for temperatures outside this range.

**Maximum Solids Size** 800 microns

**Input Shaft** Left or Right Side

**Inlet Ports** Weld-On: 4" / SCH. 40  
4" NPT, 4" Class 300 RF ANSI Flange

**Discharge Ports** Weld-On: 2" / SCH. 160  
2" NPT, 2" Class 2500 RTJ ANSI Flange

**Plunger Stroke Length** 3-1/2 inch (88.9 mm)

**Shaft Diameter** 3 inch (76.2 mm)

**Shaft Rotation** Uni-directional (See rotation arrow.)

**Oil Capacity** 32 US quarts (30.3 liters) - blank back cover  
34 US quarts (32.2 liters) - oil level back cover  
See page 5 for oil selection and specification.

**Pump Weight** 1700 lbs. (771 kg)

## Calculating Required Horsepower (kW)\*

$$\frac{\text{gpm} \times \text{psi}}{1,460} = \text{electric motor hp}^*$$

$$\frac{\text{lpm} \times \text{bar}}{511} = \text{electric motor kW}^*$$

\* hp (kW) is required application power.

## Attention!

When sizing motors with variable frequency drives (VFD): It is very important to select a motor and a VFD rated for constant torque inverter duty service and that the motor is rated to meet the torque requirements of the pump throughout desired speed range.

## Fluid End Materials

Manifold:	Nickel Aluminum Bronze (NAB) Duplex Alloy 2205 Stainless Steel 316L Stainless Steel CF3M Hastelloy CX2MW
Diaphragm/Elastomers:	FKM Buna-N Aflas EPDM
Diaphragm Follower Screw:	316 Stainless Steel Duplex Alloy 2205 Stainless Steel Hastelloy C
Valve Spring Retainer:	Polypropylene PVDF 316 SST Hastelloy C
Check Valve Spring:	Elgiloy Hastelloy C
Valve Disc/Seat:	Tungsten Carbide 17-4 Stainless Steel Nitronic 50 Hastelloy C
Plug-Outlet Valve Port:	316 Stainless Steel Duplex Alloy 2205 Stainless Steel Hastelloy C
Inlet/Outlet Valve Retainer:	316 Stainless Steel Duplex Alloy 2205 Stainless Steel Hastelloy C

## Power End Materials

Crankshaft:	Forged Q&T Alloy Steel
Connecting Rods:	Ductile Iron
Crossheads:	12L14 Steel
Crankcase:	Ductile Iron
Bearings:	Spherical Roller (outer mains) Steel Backed Babbitt (crankpin) Bronze (wristpin, center mains)

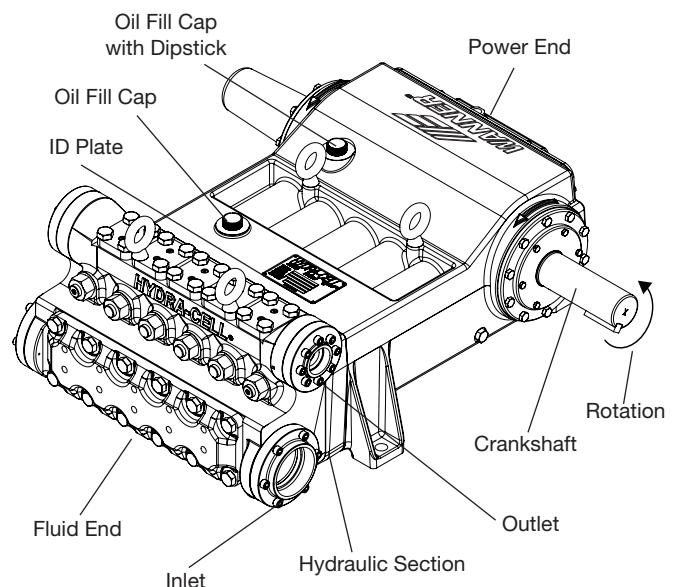

Due to the Wanner Engineering Continuous Improvement Program, specifications and other data are subject to change.

# Q155 Pro Medium Pressure | Drawings

## Threaded Version Inches (mm)

### Front View

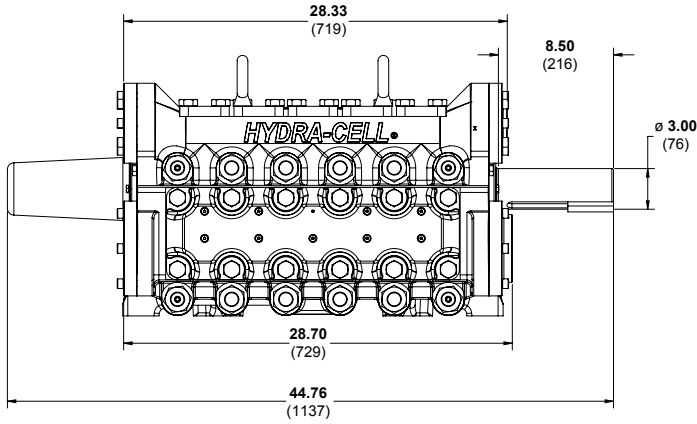

### Side View

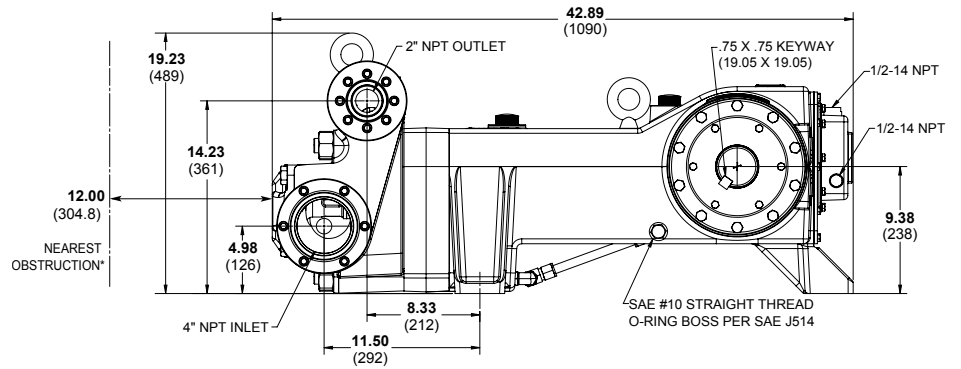

\*Contact factory for obstruction distances closer than 12 inches (304.8 mm).

### Bottom View

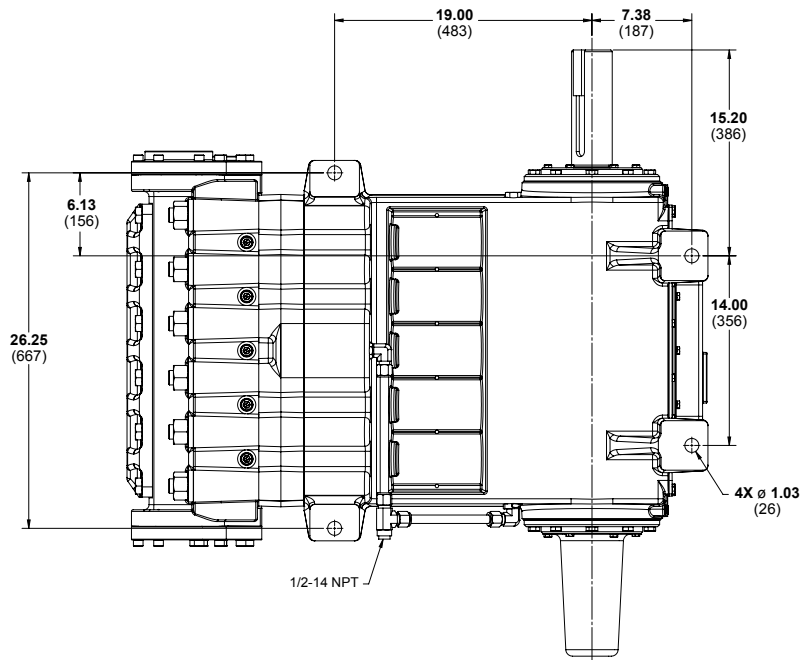

Note: Dimensions are for reference only. Contact factory for certified drawings.

# Q155 Pro Medium Pressure | How to Order

## Ordering Information

A complete Q155 Pro Series Medium Pressure Model contains 14 digits including 10 customer-specified design and materials options, for example: Q155KADTHFEMAC.

1	2	3	4	5	6	7	8	9	10	11	12	13	14
Q	1	5	5										

## Medium Pressure

Digit	Order Code	Description
1-4	Q155	<b>Pump Configuration</b> Shaft-driven
5	K	<b>Performance</b> Max. 75 gpm (284 l/min) 2571 BPD @ 3000 psi (207 bar)
	M	Max. 63 gpm (238 l/min) 2160 BPD @ 3500 psi (241 bar)
6	A	<b>Pump Head Version</b> NPT Ports, Steel
	C	Weld Neck, Steel
	D	Weld Neck, 316L Stainless Steel
	E	Weld Neck, Hastelloy C
	F	Weld Neck, Duplex Alloy 2205 Stainless Steel
	G	ANSI Flanged Ports, Duplex Alloy 2205 Stainless Steel
	R	ANSI Flanged Ports, Steel
	S	ANSI Flanged Ports, 316L Stainless Steel
	T	ANSI Flanged Ports, Hastelloy C
7	D	<b>Pump Head Material</b> Nickel Aluminum Bronze (NAB)
	G	Duplex Alloy 2205 Stainless Steel
	S	316L Stainless Steel CF3M
	T	Hastelloy CX2MW
8	A	<b>Diaphragm &amp; O-ring Material</b> Aflas
	E	EPDM (requires EPDM-compatible oil – Digit 13 oil code D)
	G	FKM
	T	Buna-N
9	D	<b>Valve Seat Material</b> Tungsten Carbide*
	H	17-4 Stainless Steel
	N	Nitronic 50
	T	Hastelloy C
10	D	<b>Valve Material</b> Tungsten Carbide*
	F	17-4 Stainless Steel
	N	Nitronic 50
	T	Hastelloy C
11	D	<b>Valve Springs</b> Elgiloy for Tungsten Carbide valves*
	E	Elgiloy
	T	Hastelloy C
	V	Hastelloy C for Tungsten Carbide valves*

Digit	Order Code	Description
12	M	<b>Valve Spring Retainers</b> PVDF
	P	Polypropylene
	S	316 Stainless Steel
	T	Hastelloy C
13	A	<b>Hydra-Oil</b> 10W30 standard-duty oil
	B	40-wt. oil
	D	EPDM-compatible oil
	H	15W50 high-temp severe-duty synthetic oil
	M	Food-contact oil
14	C	<b>Oil Level Monitor Cover</b> Float switch, normally closed (recommended)
	O	Float switch, normally open
	S	Float switch, Class I, Div. 1, Groups A, B, C, D, normally closed
	T	Float switch, Class I, Div. 1, Groups A, B, C, D, normally open
	W	Float switch, ATEX/IECEx, 4-20 mA analog output (qualification required)
	X	Float switch, ATEX/IECEx, discrete output (qualification required)
	Y	No switch, flat back cover

**Note:** The Oil Level Monitor Cover is an assembly that replaces the previous back cover on Q155 Series pumps. It contains a float switch assembly that can trigger an alarm or shutdown when pre-defined levels of high or low oil are reached. It may also be ordered without a float switch cover.



\* Tungsten Carbide valve seat and disc are a matched set and must be purchased together along with appropriate valve springs.

## Partners in over 70 countries

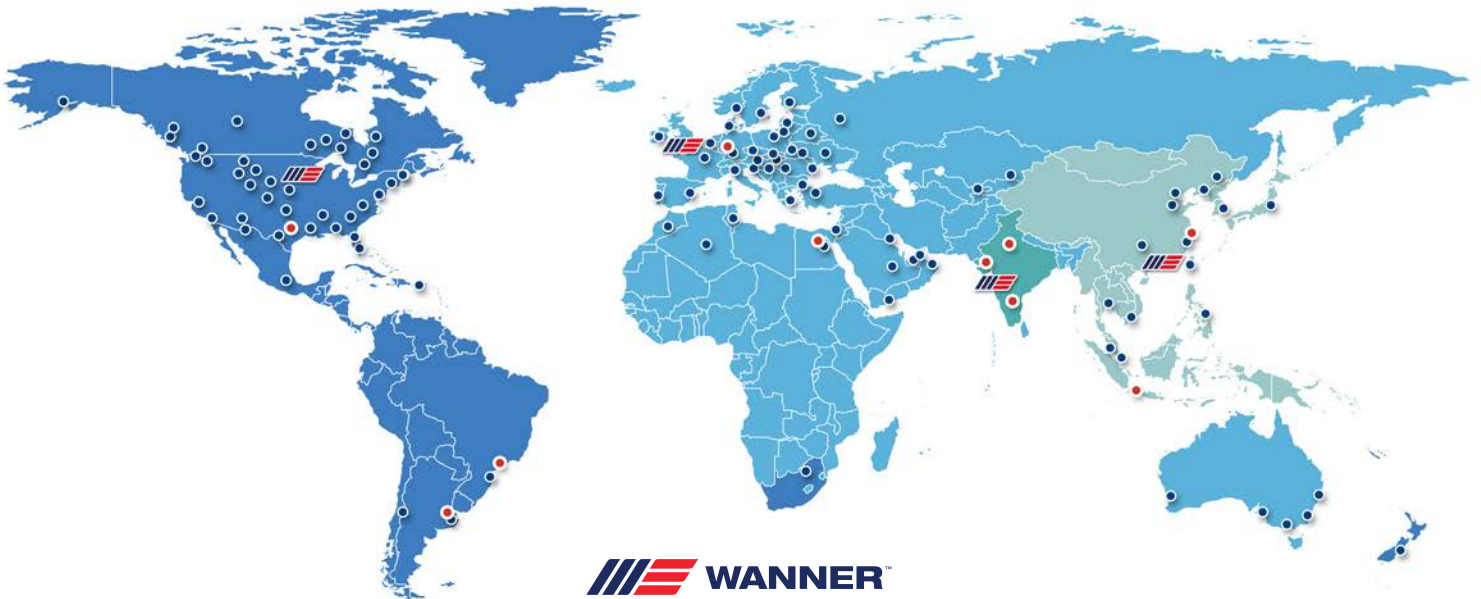



**WANNER™**  
Global Sales and Technical Support



### Americas

-  Minneapolis, Minnesota USA
-  Wichita Falls, Texas USA
-  São Paulo, Brazil
-  Buenos Aires, Argentina





### EMEA | Australia

-  Hampshire, United Kingdom
-  Cairo, Egypt
-  Remagen, Germany

### Asia | Pacific

-  Kowloon, Hong Kong
-  Shanghai, China
-  Jakarta, Indonesia

### India

-  Mumbai, India
-  New Delhi
-  Bangalore
-  Gujarat

## Wanner worldwide

GLOBAL SALES & TECHNICAL SUPPORT

### WANNER ENGINEERING, INC.

WORLD HEADQUARTERS & MANUFACTURING

Minneapolis, Minnesota USA  
t: 612-332-5681  
e: sales@wannereng.com  
Hydra-Cell.com

### REGIONAL OFFICE

Wichita Falls, Texas USA  
t: 940-322-7111  
e: sales@wannereng.com

### LATIN AMERICAN OFFICE

São Paulo, Brazil  
t: +55 (11) 99582-1969  
e: mmagoni@wannereng.com  
Hydra-Cell-Pumps.com.br

### WANNER INTERNATIONAL, LTD.

UNITED KINGDOM

Church Crookham,  
Hampshire UK GU52 8BF  
t: +44 (0) 1252 816847  
e: support@wannerint.com  
Hydra-Cell.co.uk

### WANNER PUMPS, LTD.

Kowloon, HONG KONG  
t: +852 3428 6534  
e: sales@wannerpumps.com  
WannerPumps.com

Shanghai, CHINA  
t: +86-21-6876 3700  
e: sales@wannerpumps.com  
WannerPumps.com

### WANNER INDIA PVT. LTD.

Mumbai, INDIA  
t: +91 (22) 22044766  
e: support@wannerindia.com  
WannerIndia.com

